



EXTERNAL LED LIGHTING ASSESSMENT REPORT

FOR:
BRIDGE POINT, WEYBRIDGE

A PROJECT FOR:
BRIDGE INDUSTRIAL

AUTHOR:
MOHAMED MURSHED

STATUS:
PLANNING

01908 320 099 | WWW.MBA-CONSULTANTS.CO.UK | ENQUIRIES@MBA-CONSULTANTS.CO.UK

MAPLE HOUSE | WOODLANDS BUSINESS PARK | LINFORD WOOD WEST | MILTON KEYNES | MK14 6FG

DOCUMENT MANAGEMENT

DOCUMENT REVISIONS

Rev:	Description:	By:	Date:
0	Planning Issue	MM	31.01.2022
1	Planning Issue – Layout Update	MM	27.04.2022



CONTENTS

1.0	INTRODUCTION	3
2.0	LIGHTING SOLUTION COVERING THE PROPOSED DEVELOPMENT	3
3.0	BASELINE CONDITIONS	4
4.0	DESIGN STATISTICS AND CALCULATIONS	7
5.0	RIVER WEY	8
6.0	LUMINAIRE DETAILS.....	10
7.0	CONCLUSION.....	11

1.0 INTRODUCTION

1. MBA Consulting Engineers Ltd. has been commissioned by Bridge Industrial to produce an External Lighting Assessment report in support of the Full Planning Application for the proposed development at Bridge Point, Weybridge within the Surrey Borough of Elmbridge.
2. The proposed redevelopment consists of the demolition of existing buildings and the development of 3 industrial units with a public road between the developments. The 3 units are split with unit 100 adjacent to the river Wey and units 210 and 220 units adjacent to Weybridge Road with a public road (Addlestone Road) as the road connection. The new development will consist of ancillary office accommodation, new vehicular access, associated external yard areas, HGV and car parking (including electric vehicle charging), Vehicle servicing, external lighting, landscaping, infrastructure and associated works.
3. The total lighting scheme covers all the external areas, the main buildings including all external areas to the dock doors, car parking spaces, cycle storage areas, loading bays, services yards and access roads.
4. This assessment also sets out the details of the measures that will be taken to ensure that the external lighting design focuses on limiting the light spillage onto the adjacent river (River Wey).
5. The scheme covering the building is based on the use of LED luminaires fixed to columns and the building façades as detailed on the accompanied drawing, 21-329-EX-PL-001.
6. The lighting layouts have been based on the architect's layout undertaken by UMC, drawing reference 21490-UMC-ZZZZ-SI-DR-A-0602 [A].

2.0 LIGHTING SOLUTION COVERING THE PROPOSED DEVELOPMENT

1. Current versions of the following lighting standards, policies and guidance documents forms the basis within this report for assessment and were consulted during and post completion of the theoretical lighting design: -
 - A. National Planning Policy Framework
 - B. Clean Neighborhoods and Environment Act (CNEA)
 - C. Environmental Protection Act
 - D. HSE Executive Lighting at Work (ISBN 978 0 7176 1232 1)
 - E. British Standards, Lighting of Outdoor Work Places (BS EN 12464)
 - F. British Standards, Accessible & Inclusive Built Environment (BS 8300-1)
 - G. British Standards, Photobiological Safety of Lamp Systems (BS EN 62471)
 - H. CIBSE Lighting Guide LG1, The Industrial Environment
 - I. CIBSE Lighting Guide LG6, The Outdoor Environment
 - J. ILP Technical Report TR12 Lighting of Pedestrian Crossings
 - K. ILP Guidance Notes for the Reduction of Obtrusive Light
 - L. ILP Guidance Notes Guidance Notes for Bat & Artificial Lighting in UK.
2. Care has been taken when specifying the luminaires to ensure the appropriate products will greatly reduce spill light, and glare to and around site boundaries and prevent sky glow.
3. The selected luminaires have the following specific design features:
 - Full cut-off
 - Flat and horizontal ergonomics
 - Backlight Shield
 - High-Efficient LED Lamps
 - 0% ULOR ensuring night-time friendly.

4. Best lighting practice design guidelines have been followed to achieve the criteria outlined in The Institution of Lighting Professionals: Guidance Notes for the Reduction of Obtrusive Light, covering Environmental Zones E0 to E4.
5. With the proposed luminaires not having an upward light ratio (ULR) of more than 0% and strategically placed - The proposed design solution meets the criteria of environmental zone E0, Lighting Environment classification of "Dark". This is more than sufficient as the proposed site is classified as being E3 (Suburban), please see extracts below.

3.0 BASELINE CONDITIONS

1. Limiting values are placed on the allowable levels of light trespass, sky glow etc. that should be present in these areas, qualitative descriptions and limits applicable to each of the Environmental Zones from the ILP 2020 guidelines are identified in tables 1 and 2 below.
2. Based on the tables below, the Site falls under 'Zone E3' classification.

ZONE	SURROUNDING	LIGHTING ENVIRONMENT	EXAMPLES
E0	Protected	Dark	Unesco starlight reserves, IDA dark sky parks
E1	Natural	Intrinsically dark	National parks, areas of outstanding natural beauty
E2	Rural	Low district brightness	Village or relatively dark outer suburban locations
E3	Suburban	Medium district brightness	Small town centres or suburban locations
E4	Urban	High district brightness	Town/city centres with high levels of night time activity

Table 1 - Environmental Zones

ENVIRONMENT ZONE	SKY GLOW ULR [MAX%] ≤	LIGHT INTRUSION INTO WINDOWS EV (LUX)		LUMINAIRE INTENSITY I (CANDELAS)		BUILDING LUMINANCE PRE-CURFEW Average L (cd/m ²) ≤
		Pre-Curfew	Post-Curfew ≤	Pre-Curfew	Post-Curfew	
E0	0	0	0	0	0	0
E1	0	2	0	2,500	0	0
E2	2.5	5	1	7,500	500	5
E3	5.0	10	2	10,000	1,000	10
E4	15.0	25	5	25,000	2,500	25

Table 2 - Obstructive Light Limitations for Exterior Lighting Installations - General Observers

- The proposed Holophane luminaires have an ULR of 0% and drastically reduce the upward spread of light near to and above the horizontal. The most sensitive/critical zones for minimising sky glow are those between 90 and 100 degrees as shown below and referred to as the lower, upward lighting zone (UL).

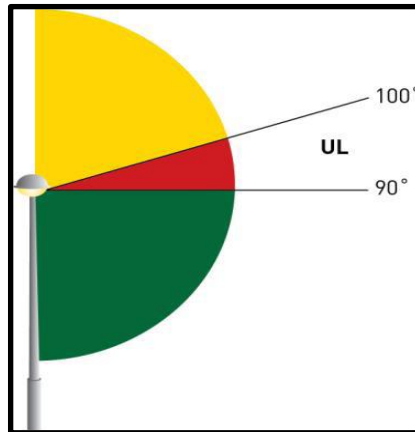

Figure 1 - Image indicating the angle which upward light appears

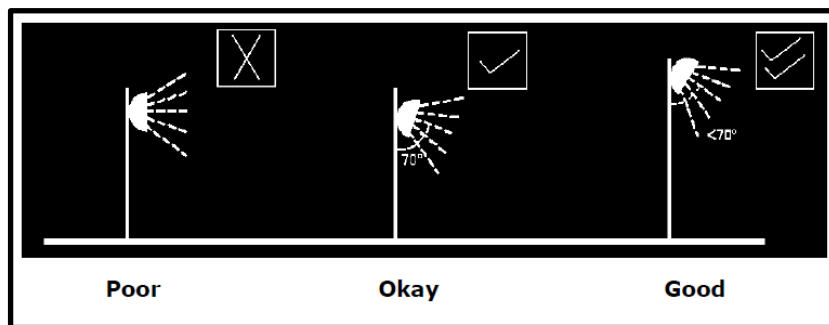

Figure 2 - Image indicating poor & good ranges of light angles

- At the designed mounting heights, the chosen luminaires ensure that greater spacing between luminaires is achieved thus reducing the number of lighting points overall.
- Glare has been kept to a minimum by ensuring that the main beam angle of all the luminaires directed towards any potential observer is not more than 70 degrees.

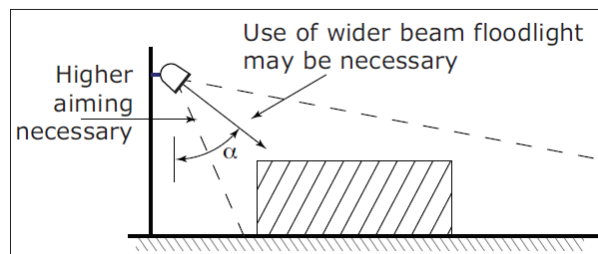

Figure 3 - Lower Mounting height - More spill & Glare

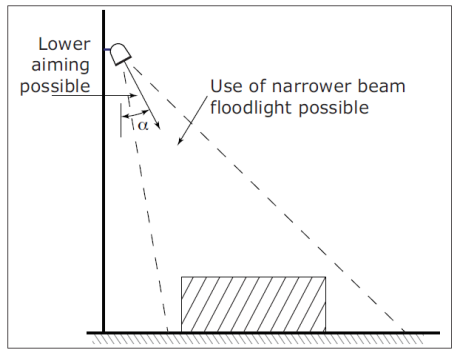

Figure 4 - Higher Mounting Height - Less Spill & Glare

6. The location of the proposed development is indicated to be within an area of relatively high light pollution. This is indicated in the image below, which shows how the center of Weybridge is between the levels of 18.5 and 17.5.
7. With the precautions taken with the fittings specified, and the careful design, the amount of upward light has been mitigated. By mitigating this upward light, the development shouldn't add to this level of light pollution.

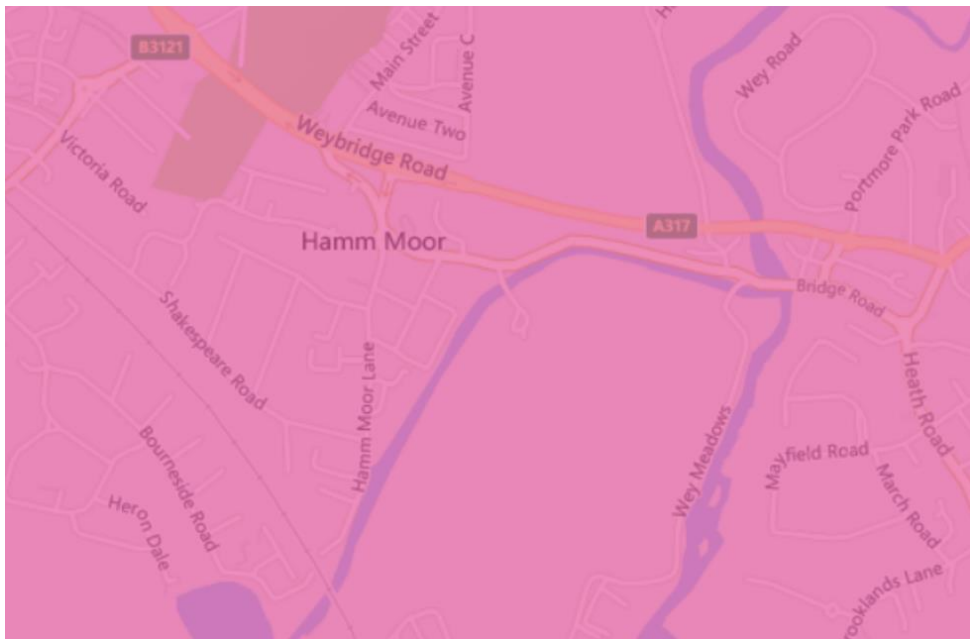

Figure 5 - Image indicating light pollution

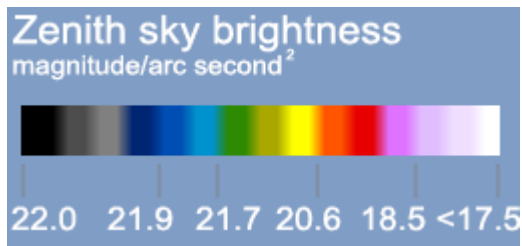

Figure 6 - Image of Legend for Light Pollution

4.0 DESIGN STATISTICS AND CALCULATIONS

- The following table details the design statistics achieved within the various areas of the development and should be read in conjunction with the external lighting drawing provided.

Statistics				
Description	Symbol	Avg	Min	Min/Avg
SPILL	+	0 lux	0 lux	N/A
Unit 100 Access Road - 20/0.40Uo	◇	21 lux	11 lux	0.52
Unit 100 Rear Walkways - 10/0.40Uo	+	10 lux	4 lux	0.40
Unit 210 Car Park - 10/0.25Uo	+	11 lux	3 lux	0.27
Unit 210 Cycles	+	14 lux	12 lux	0.86
Unit 210 Rear Walkways - 10/0.40Uo	+	10 lux	5 lux	0.50
Unit 210 Service Yard - 20/0.40Uo	+	24 lux	13 lux	0.54
Unit 210/220 Shared Access - 20/0.40Uo	+	21 lux	9 lux	0.43
Unit 220 Car Park - 10/0.25Uo	+	11 lux	3 lux	0.27
Unit 220 Cycles	+	12 lux	6 lux	0.50
Unit 220 Rear Walkways - 10/0.40Uo	+	12 lux	5 lux	0.42
Unit 220 Service Yard - 20/0.40Uo	+	21 lux	15 lux	0.71
Visitor Parking - 10/0.25Uo	+	20 lux	10 lux	0.50
Unit 100 Car Park - 10/0.25Uo	+	11 lux	3 lux	0.27
Unit 100 Cycles	+	10 lux	7 lux	0.70
Unit 100 Service Yard - 20/0.40Uo	+	21 lux	9 lux	0.43

Table 3- Design Statistics

- The results obtained fall in line with the respective guidelines Environmental Zones E0 inclusive as detailed in tables 2 of this report.
- As further detailed on the drawing any potential light spill over the boundaries into adjoining areas has been kept to the minimum and it's shown on the drawing in a blue contour line which clearly indicates the expected spill zone.
- The below drawing indicates the positions and the heights of the lighting columns. These have been positioned to ensure that the potential spill is reduced, especially on the boundary where the nearby River Wey comes into close proximity.
- From the results table above, it indicates all the average Lux levels complying with the guide set out within the documents stated in section 2.0. This ensures a fully compliant design which meets the criteria previously set out.

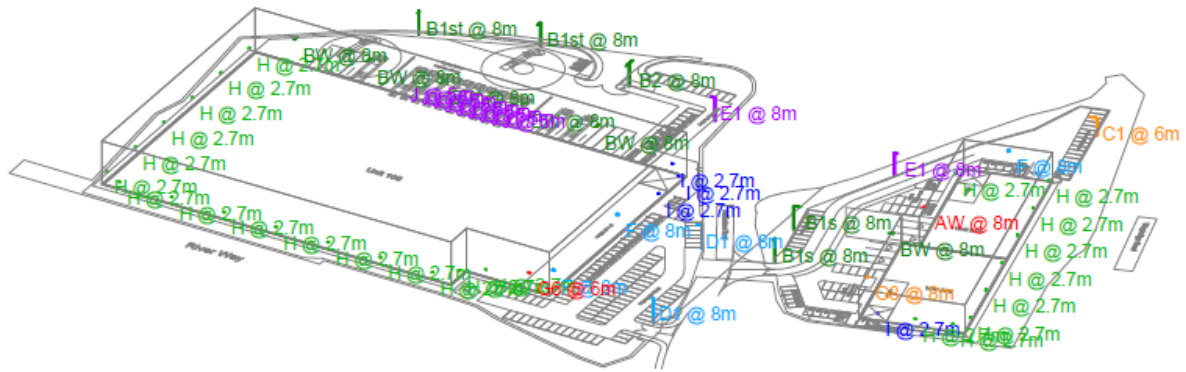

ISOMETRIC VIEW
NTS

Figure 7 - Locations of Luminaires within the development

6.0 RIVER WEY



Figure 1- Site plan illustrating River Wey location

1. The above figure shows the River Wey adjacent to the Southern boundary, highlighted in yellow.

2. The following measures have been taken to minimise the light spill over the River:
 - Flat-cut off luminaires with backlight shields have been selected for the lighting columns positioned closest to the River
 - Use of narrow beam light sources to provide appropriate illuminance for only the service yard areas' intended use which minimises any light spillage onto the River.
3. As per MBA's drawing 21-329-PL-EX-001, the maximum light spill onto the River from the proposed External lighting scheme is approximately 1 lux maximum (figure 2) and this only occurs over a small area highlighted in yellow in the figure 2 below. Note that 1 Lux achieved is very low compared to the maximum 10lux emitted from a clear full moon as indicated under point 6, Table 5 below.
4. The lux plot has been obtained using highly accurate software which does not take into consideration trees between the site and the River. Instead, it assumes a flat ground level throughout which will typically show higher light spillage. Note that, the trees will absorb an amount of the light spill therefore further reducing the 1 lux.
5. In addition to the above, the light spillage onto the River is caused by indirect lighting from light bounced off the ground on site, this tends to appear higher than usual on the lux plot but is low and almost impossible to see with the human naked eye.

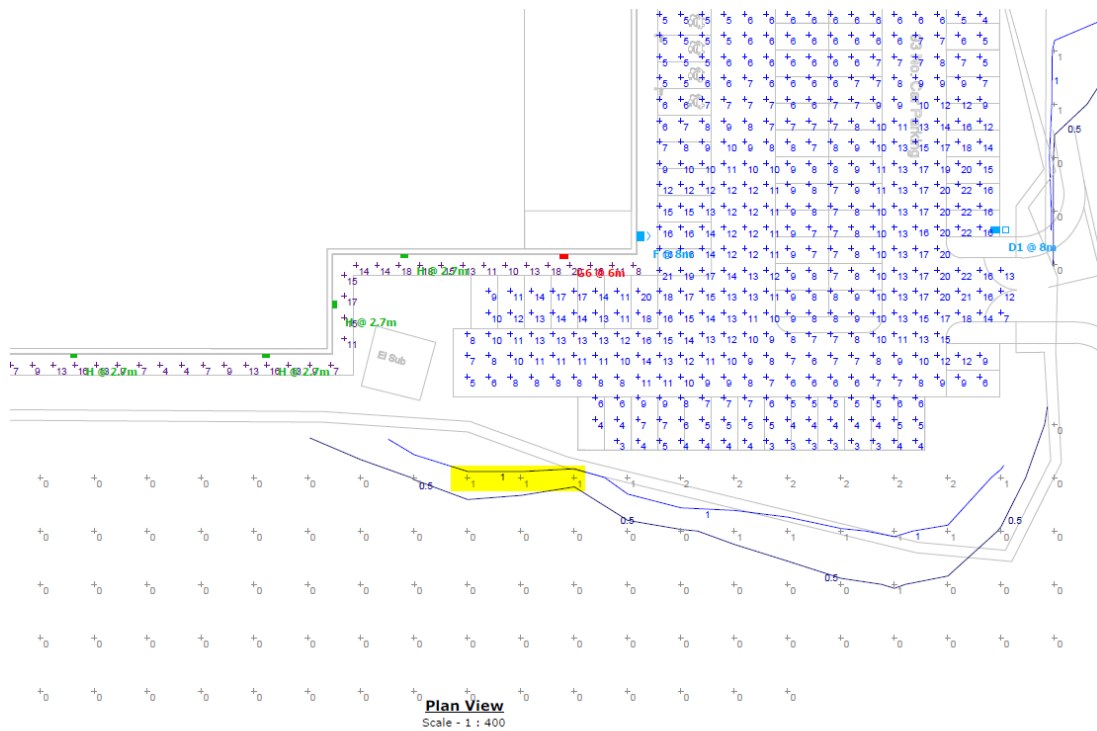

Figure 2- Site plan showing point of maximum lux level on River Wey

6. The following table is intended to provide some points of reference for those unfamiliar with lux as a measurement of light levels. The data represents a conservative example of the lux measurements for the given conditions found worldwide:

Light Source	Horizontal Lux
Full Moon to Twilight	0.1 to 10
Typical City Centre Car Park	20 to 40
Street Lights – Housing Estate	2.5 to 10
Street Lights – Residential Estate	1 to 6
Office/Classroom	400 to 750
Professional Stadium	2,000 to 3,500
Sunny Day	30,000 to 50,000

Table 5 – Lux levels – References

6.0 LUMINAIRE DETAILS

6.1 D-Series - Column Mounted LED Luminaire.

1. The D-SERIES Streetlight luminaire has a single-piece die-cast aluminium housing that conforms to EN1706 AC-46500 with integral heat sink fins to optimise thermal management through conductive cooling.
2. LED modules are IP65 with individual lenses, and high-grade aluminium housing to transfer heat away from the LEDs and dissipate through the finned housing for cooling.
3. The LED driver is mounted in direct contact with the finned housing for cooling to promote low operating temperature and long system life.
4. The housing is completely sealed against moisture and environmental contaminants (IP65).
5. With 0% upward light ratio this luminaire complies with Environmental Zones E0 to and including E4.



6.2 Polar - Wall Mounted Led Luminaire

1. Holophane Polar 1/AR is a wall mounted luminaire made up of a die cast aluminium body, coated with polyester anticorrosion powder, silver colour, 4mm thick tempered transparent glass, silicon gasket, electronic driver 220-240V 50/60Hz. Manufactured in accordance with EN/IEC 60598-1:2018.
2. Both luminaire body and LED module are sealed to IP66 and rated IK08. Drivers and LED are mounted separately from each other to promote low operating temperatures and long system life.

3. With 0% upward light ratio this luminaire complies with Environmental Zones E0 to and including E4.

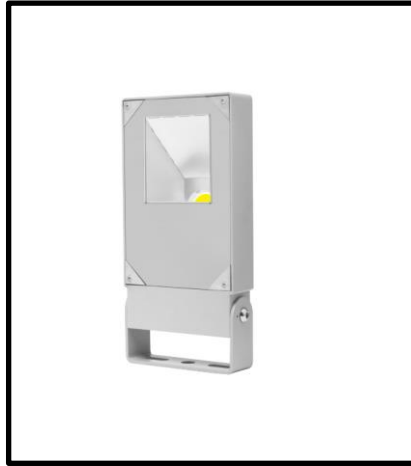

6.3 Denver - Wall Mounted Led Luminaire

1. Holophane Denver iD is wall mounted luminaire and consists of a 2-part body and a removable LED module manufactured from LM6 marine grade die-cast aluminium with integrated thermal management properties.
2. The LED module optical arrangement consists of LEDs with individual optical lenses surrounded by a patented white Transition Zone to reduce perceived glare. This is sealed behind high-transparency 'hydrophilic' glass. Both luminaire body and LED module are sealed to IP65 and rated IK10.
3. Drivers and LED are mounted separately from each other to promote low operating temperatures and long system life.



7.0 CONCLUSION

1. The total lighting solution has been carefully designed to ensure the immediate environment has been protected including the adjacent River Wey.
2. The illumination that would normally be free flowing from site boundaries has been restricted and has been further designed to mitigate any potential impact within ecology zones.
3. Careful consideration has also been taken to ensure no loss of amenity due to glare through shielding of the lamps, choice of luminaires and efficient mounting heights.

4. Overall, the proposed development requires appropriate levels of illumination throughout to satisfy the traditional use of the site. This report demonstrates a scheme, which meets all requirements of the user and remains considerate of the local environment in its design and approach.

CDM DESIGNER RISK INFORMATION
 IN ADDITION TO THE HAZARDS/RISKS NORMALLY
 ASSOCIATED WITH THE TYPES OF WORK DETAILED
 ON THIS DRAWING, NOTE THE FOLLOWING:-

CONSTRUCTION
MAINTENANCE/CLEANING
DECOMMISSIONING/DEMOLITION

FURTHER INFORMATION CAN BE FOUND ON
 DESIGNER RISK ASSESSMENT NUMBER:
 IT IS ASSUMED THAT ALL WORKS WILL BE CARRIED
 OUT BY A CONTRACTOR COMPETENT UNDER CDM
 2015 WORKING TO AN APPROVED METHOD
 STATEMENT

Notes

- DO NOT SCALE THIS DRAWING.
- ALL DIMENSIONS ARE IN MILLIMETERS UNLESS OTHERWISE STATED.
- THIS DRAWING IS TO BE READ IN CONJUNCTION WITH ALL OTHER RELEVANT DRAWINGS AND SPECIFICATIONS.

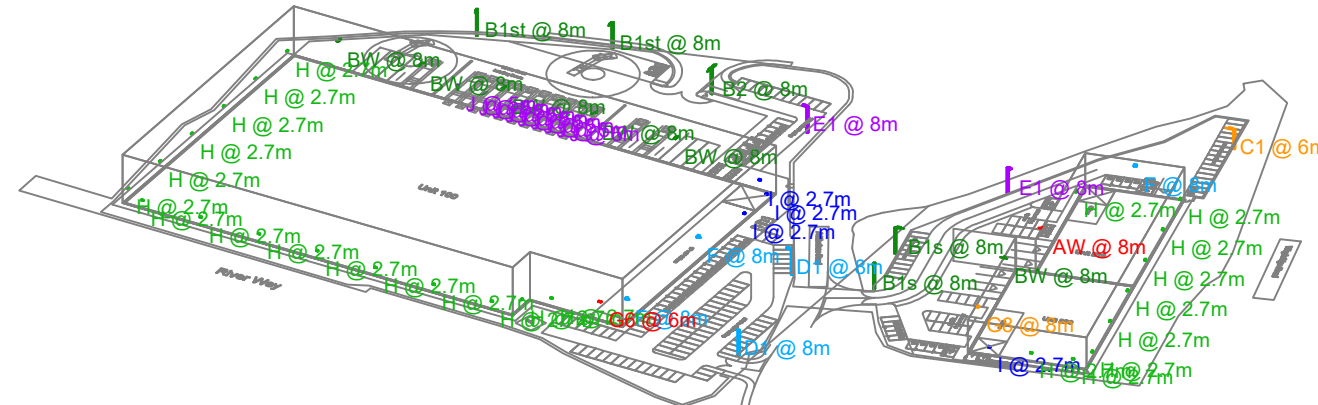

ISOMETRIC VIEW
NTS

Symbol	Label	Quantity	Manufacturer	Catalog Number	Description	Wattage
	AW	1	HOLOPHANE EUROPE LIMITED	DSX1.2.LA224.FW on Wall Bracket at 8m AFFL	D-Series 1 Luminaire	208
	B1s	2	HOLOPHANE EUROPE LIMITED	DSX1.2.LA164.FW.BLS on 8m Column and Backlight Shield.	D-Series 1 Luminaire with Back Light Shield	131
	B1st	2	HOLOPHANE EUROPE LIMITED	DSX1.2.LA164.FW.BLS on 8m Column and Backlight Shield. 5 Degree Tilt Bracket	D-Series 1 Luminaire with Back Light Shield	131
	B2	1	HOLOPHANE EUROPE LIMITED	2 x DSX1.2.LA164.FW on 8m Column	D-Series 1 Luminaire	262
	BW	6	HOLOPHANE EUROPE LIMITED	DSX1.2.LA164.FW on Wall Bracket at 8m AFFL	D-Series 1 Luminaire	131
	C1	1	HOLOPHANE EUROPE LIMITED	1 x DSX0.1.LA104.FW on 6m Column	D-Series 0 Area luminaire	81
	D1	2	HOLOPHANE EUROPE LIMITED	1 x DSX0.1.LA104.BLC on 8m Column. With Integral Backlight Shield	D-Series 0 Area luminaire	81
	E1	2	HOLOPHANE EUROPE LIMITED	1 x DSX0.1.LA064.BLC on 8m Column. With Integral Backlight Shield	D-Series 0 Area luminaire	45
	F	3	HOLOPHANE EUROPE LIMITED	WAP.1.LA094.FW at 8m AFFL	WALLPACK	81
	G6	1	HOLOPHANE EUROPE LIMITED	WAP.1.LA064.FW at 6m AFFL	WALLPACK	50
	G8	1	HOLOPHANE EUROPE LIMITED	WAP.1.LA064.FW at 8m AFFL	WALLPACK	50
	H	24	HOLOPHANE EUROPE LIMITED	DWL.1.LA014.HN.W007 at 2.7m AFFL	Denver ID Wall	6.5
	I	4	HOLOPHANE EUROPE LIMITED	DWL.1.LA024.FW.W011 at 2.7m AFFL	Denver ID Wall	10.3
	J	9	HOLOPHANE EUROPE LIMITED	TBHF.POL.1.7026AR403 0GL at 5m Zero Tilt	7026 - POLAR 1 30W MOD. AR 4000K	30

Statistics				
Description	Symbol	Avg	Min	Min/Avg
SPILL	+	0 lux	0 lux	N/A
Unit 100 Access Road - 20/0.40Uo	◇	21 lux	11 lux	0.52
Unit 100 Rear Walkways - 10/0.40Uo	+	10 lux	4 lux	0.40
Unit 210 Car Park - 10/0.25Uo	+	11 lux	3 lux	0.27
Unit 210 Cycles	+	14 lux	12 lux	0.86
Unit 210 Rear Walkways - 10/0.40Uo	+	10 lux	5 lux	0.50
Unit 210 Service Yard - 20/0.40Uo	+	24 lux	13 lux	0.54
Unit 210/220 Shared Access - 20/0.40Uo	+	21 lux	9 lux	0.43
Unit 220 Car Park - 10/0.25Uo	+	11 lux	3 lux	0.27
Unit 220 Cycles	+	12 lux	6 lux	0.50
Unit 220 Rear Walkways - 10/0.40Uo	+	12 lux	5 lux	0.42
Unit 220 Service Yard - 20/0.40Uo	+	21 lux	15 lux	0.71
Visitor Parking - 10/0.25Uo	+	20 lux	10 lux	0.50
Unit 100 Car Park - 10/0.25Uo	+	11 lux	3 lux	0.27
Unit 100 Cycles	+	10 lux	7 lux	0.70
Unit 100 Service Yard - 20/0.40Uo	+	21 lux	9 lux	0.43

PL2	27.04.22	RE-ISSUED FOR PLANNING	DH
PL1	31.01.22	ISSUE FOR PLANNING	DH
REV:	DATE:	AMENDMENTS:	APPRD:

mba
CONSULTING ENGINEERS

Maple House, Woodlands Business Park,
Lifford Wood West, Milton Keynes MK14 6FG
Telephone: +44 (0) 1908 520 099
Email: enq@mba-consultants.co.uk
Web: www.mba-consultants.co.uk

BRIDGE

CLIENT:

**WEYBRIDGE BUSINESS PARK
WEYBRIDGE**

PROJECT:

**INDICATIVE EXTERNAL LIGHTING
LAYOUT**

TITLE:

DRAWING NUMBER: **21-329-PL-EX-001**

REV: PL2	STATUS: PLANNING	DESIGNED BY: MM
SCALE: 1:500@A1	DATE: JAN 2022	DRAWN BY: JEG

